



# FRONTIER™ 5707

Multi Centrifuges



Distributed by:  
Safety Emporium  
PO Box 1003  
Blackwood, NJ 08012  
Ph: (866) 326-5412 toll-free  
Fax: (856) 553-6154  
esupport@safetyemporium.com  
www.safetyemporium.com

## **Compact Low-Speed Centrifuge with a Modern Touch-Wheel Interface Ideal for General Low Throughput Lab Applications**

Frontier 5707 is a reliable compact low-speed centrifuge ideal for processing small number of blood collection and urine tubes or standard conical tubes. Depending on the kit it might include a pre-installed rotor with different capacity: Angle rotor which can handle 8 x 15 ml RB or 4 x 15 ml FA tubes or Angle combi rotor which can handle 4 x 15 ml or 4 x 50 ml RB/FA tubes. Both rotors are suitable for round and conical bottom tubes. Designed with convenient operation in mind, Frontier 5707 features a uniquely designed splash-proof front panel with Touch-Wheel control on an intuitive interface.

### **Unique Features:**

- Designed for ease of operation, the Frontier 5707 features convenient control on a protective splash-proof interface, which allows for responsive operation—even when wearing gloves.
- Enclosing all its functionalities within a small footprint, the Frontier 5707 saves valuable space on the lab bench.
- In order to ensure adaptability for various applications and satisfy different customers' requirements, there are 2 kits available that can include: an Angle rotor for 8 x 15 ml RB tubes or 4 x 15 ml FA tubes, or a combi Angle rotor 4 x 15 ml or 4 x 15 ml RB/FA. For clinical use, the rotor can directly accommodate multiple sizes of blood and urine tubes, or these can be paired with additional accessories. For research purposes, the kit can support 1.5/2.0 ml microtubes with additional accessories, or 15 ml tubes.

# FRONTIER™ 5707 *Multi Centrifuges*

## Designed for easy operations and great user experience

- Easy-to-Use touch-wheel interface for parameter adjustments
- Convenient interface shows both set and actual parameters
- One-touch toggling between RPM/RCF, Acc/Dec
- Double-line LCD display with light blue backlight
- Audible signal at the end of each run with melody
- 10 acceleration/deceleration settings
- 99 memory sets to quickly store and recall commonly used parameters

## Safety features enclosed within small footprint

- Microprocessors control to help prevent accidents and protect both the user and the equipment
- Rotor imbalance sensor systems stops the unit when it detects an imbalanced load
- Sturdy mechanical lid with locking system

## Flexible rotor selections and kits to cover wide range of general laboratory and diagnostic applications

- Maintenance-free induction motor produces maximum G-force of 4445 x g
- Speeds up to 6800 rpm and quick spin for short runs
- Angle rotor which can handle 8 x 15 ml RB or 4 x 15 ml FA tubes or Angle combi rotor which can handle 4 x 15 ml or 4 x 50 ml RB/FA tubes

Distributed by:  
Safety Emporium  
PO Box 1003  
Blackwood, NJ 08012  
Ph: (866) 326-5412 toll-free  
Fax: (856) 553-6154  
[esupport@safetyemporium.com](mailto:esupport@safetyemporium.com)  
[www.safetyemporium.com](http://www.safetyemporium.com)



# FRONTIER™ 5707 Multi Centrifuges

## Specifications

Model	FC5707+R05	FC5707+R09
Order No.	30393189	83041073
Speed Range	200 rpm – 6800 rpm; 10 rpm / increments	
Maximum RCF	4445 x g; 10 x g / increments	
Rotor in the Package	Angle Rotor: 8 x 15 ml RB or 4 x 15 ml FA	Angle Rotor: 4 x 50 ml RB/FA or 15 ml RB/FA
Temperature Range	Air cooled	
Refrigerant	N/A	
Running Time	Quick Spin, 10 sec to 99 hr 59 min, or continuous	
Noise Level	≤ 60 + 2 dB(A)	
Acc/Dec Levels	10/10	
Allowable Density at Maximum Speed	1.2 g/ml	
Allowable Kinetic Energy	845 Nm	1341 Nm
AC Power	110 - 230 V/50 - 60 Hz	
Voltage Fluctuation	± 10 %	
Current Consumption	0.8 – 0.4 A	
Power Consumption	50 W	
Dimensions (W x D x H)	277 x 351 x 231 mm / 10.9 x 13.8 x 9.0 in	
Net Weight (with rotor)	11 kg / 24.3 lb	
Shipping Dimensions (W x D x H)	370 x 460 x 360 mm / 14.6 x 18.1 x 14.7 in	
Shipping Weight (with rotor)	13.5 kg / 29.8 lb	
Ambient conditions (EN/IEC 61010-1)	Environment	For indoor use only
	Altitude	Use up to an altitude of 2000 m
	Ambient temperature	5 °C up to 35 °C
	Max. relative humidity	Max. relative humidity 80 % for temperatures up to 31 °C, Decreasing linearly to 50 % relative humidity up to 35 °C.
EMC	EN/IEC 61326-1 Class B emissions, Basic immunity, FCC Class B emissions	
Not suitable for use in hazardous environments.		

## Accessories

	Order No.	30472305
	Description	Rotor Angle 8 x 15 ml RB or 4 x 15 ml FA
	Compatible with	FC5707+R05
	Max. Speed	6800 rpm
	Max. RCF	4445 x g

### Accessories

Order No.	Description	Vol./Tube	Diameter	Tube Type	No. of Tubes/Rotor
Without Adapter	Rotor Angle 8 x 15 ml RB or 4 x 15 ml FA	15 ml	17 mm	Round bottom	8
				Conical bottom	4
30130889	Adapter 1 x 7 ml D13 mm Vac/Sar, 2 pk	7 ml	13 mm	Round bottom / Vacutainer® / Sarstedt	8
30130890	Adapter 1 x 5 ml D13 mm Vac/Sar, 2 pk	5 ml	13 mm	Round bottom / Vacutainer® / Sarstedt	8
30130886	Adapter 1 x 1.5/2.0 ml D11 mm, 6 pk	1.5/2.0 ml	11 mm	Microtube	8
83041036	Adapter 1 x 1.1-5 ml D15 mm Vac/Sar, 2 pk	1.1 – 5ml	15 mm	Vacutainer® / Sarstedt	8

# FRONTIER™ 5707 Multi Centrifuges

	Order No.	83041009
	Description	Rotor Angle 4 x 50 ml RB/FA or 15 ml RB/FA
	Compatible with	FC5707+R09
	Max. Speed	6800 rpm
	Max. RCF	4445 × g

## Accessories

Order No.	Description	Vol./Tube	Diameter	Tube Type	No. of Tubes/Rotor
Without Adapter	Rotor Angle 4 x 50 ml RB/FA or 15 ml RB/FA	50 ml	29 ml	Round bottom / Conical bottom	4
		15 ml	17 ml	Round bottom / Conical bottom	4

### Shortcut list:

ID – auto rotor identification

Hi – version with higher speed

Vac – Vacutainer®

Sar – Sarstedt

FA – Conical bottom / Falcon®

FB – Flat bottom

RB – Round bottom

Rim – Skirted conical bottom

## Other Standard Features and Equipment

Microprocessor control, Imbalance switch-off, Audible signal at the end of each run with melody options, Emergency release, 99 memory sets, Ten acceleration and ten deceleration rates, Pre-selection of running time from 10 sec to 99 hr 59 min or continuous, Quick spin for short runs.

## Compliance

See Declaration of Conformity available CE Declarations | OHAUS

## Outline Dimensions

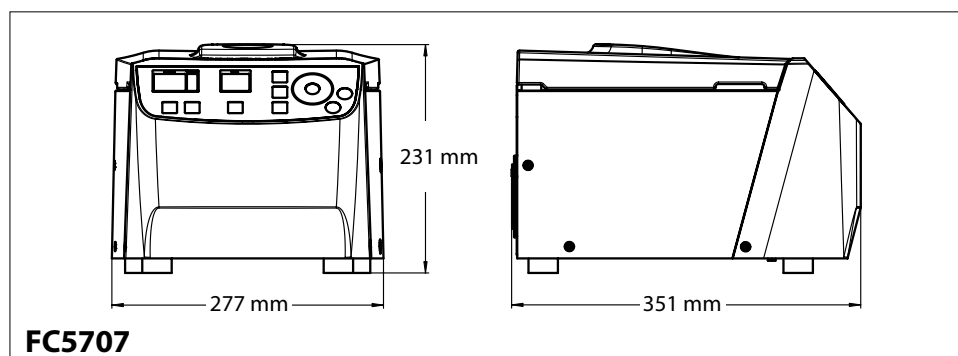

Distributed by:  
 Safety Emporium  
 PO Box 1003  
 Blackwood, NJ 08012  
 Ph: (866) 326-5412 toll-free  
 Fax: (856) 553-6154  
[esupport@safetyemporium.com](mailto:esupport@safetyemporium.com)  
[www.safetyemporium.com](http://www.safetyemporium.com)

30775548\_C 20250812 © Copyright OHAUS Corporation

### OHAUS CORPORATION

Tel: 800.672.7722  
 973.377.9000  
 Fax: 973.944.7177

[www.ohaus.com](http://www.ohaus.com)

*The management system governing the manufacture of this product is ISO 9001:2015 certified.*



Click or scan for the web

