

Reloading Procedure

For Reloading Model Number
SELF SERVICE 0930001
with Reload Kit 85-994

RUSOH™
ELIMINATOR™

**SELF SERVICE, MULTI-PURPOSE, RELOADABLE
DRY CHEMICAL FIRE EXTINGUISHER**



- After each use, the Eliminator™ fire extinguisher must be reloaded with a new CO₂ cartridge and a new agent cartridge.
- Watch the Reloading Procedure video at www.rusoh.com and read this procedure before reloading the extinguisher.
- Refer to the Owner's Manual for installation, operation, 30-day inspection, annual inspection, and warranty information.

GETTING ACQUAINTED

The reloading kit contains a replacement agent cartridge and a special cap that holds the replacement CO₂ cartridge (Fig. A). The agent cartridge is fully loaded with the dry chemical extinguishing agent. A white dust gasket, a yellow tamper seal, and a spare red CO₂ cartridge gasket are located under the cap's hinged door (Fig. B).

IMPORTANT: Wrench set, PN 81-500, is required for this procedure.
To order, visit rusoh.com.

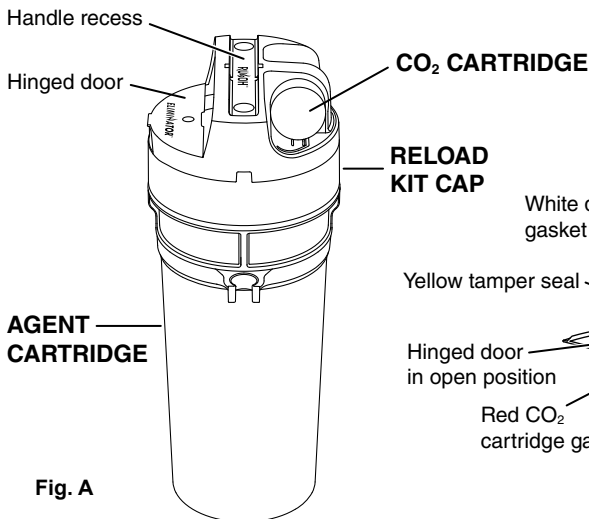

**RELOAD
KIT CAP**

Fig. B

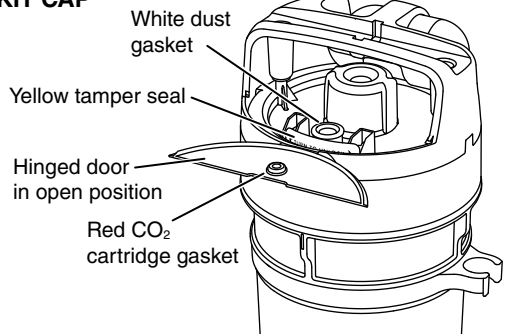

SAVE THIS RELOADING PROCEDURE FOR FUTURE REFERENCE.

RELOADING PROCEDURE

- **CAUTION!** Protective eyewear is recommended when performing the reloading procedure.
- **IMPORTANT:** The Reloading Procedure must be performed by an individual who has read these instructions and watched the Reloading Procedure video at www.rusoh.com.
- **CAUTION!** Failure to comply with the Eliminator™ Reloading Procedure will void the warranty and may result in property damage and/or bodily harm. **Reload only with the genuine Eliminator™ Reloading Kit for your Eliminator™ model number.**

Fig. C



- **NOTE:** The **agent cartridge** contains 6 pounds of Eliminator™ multi-purpose dry chemical extinguishing agent that includes monoammonium phosphate, mica, talc, and amorphous silica (HMIS 1-0-0). The extinguishing agent is nontoxic.
- **NOTE:** The **CO₂ cartridge** is a removable component filled with compressed liquid CO₂ (HMIS 1-0-3).

Refer to www.rusoh.com for the Safety Data Sheets (SDS) for these components.

⚠ DANGER!

- CO₂ cartridge is under high pressure. Do not puncture or damage CO₂ cartridge.
- Do not heat or locate CO₂ cartridge near a heat source, such as an engine or stove.
- Discharge from CO₂ cartridge is very cold and can cause frostbite.

STEP 1 *Prepare your work area.*

Place drop cloths, or other protective covering, in the area where you will be performing the reload procedure.

STEP 2 *Confirm extinguisher is not pressurized.*

⚠WARNING! Before removing CO₂ cartridge, verify that extinguisher is not pressurized. Aim nozzle upwards into a large garbage bag. Then slowly squeeze the hose valve lever. Valve lever should be easy to squeeze and should return to original position. Replace valve assembly if it does not function as stated.

STEP 3 *Remove CO₂ cartridge.*

1. Squeeze the ribbed sides of the red CO₂ cartridge cover, and lift it open. Remove CO₂ cartridge by twisting cartridge **clockwise**. A strap wrench or adjustable pliers may be needed if the cartridge is snug (Fig. D).

NOTE: The CO₂ cartridge has reverse threads, so it turns opposite of normal threaded components.

2. Discard the spent CO₂ cartridge following the Disposal Procedure on page 8.

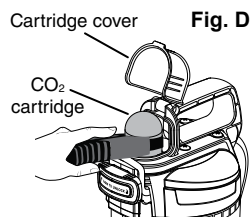

STEP 4 *Remove discharge head from agent cartridge.*

Use the Eliminator™ wrench set (**sold separately**) to loosen the discharge head from the agent cartridge, as described below:

1. Pull the hose out of the hose clip (Fig. E).
2. Place the cartridge wrench on a level floor* with the textured footrest facing up. Set the bottom of the extinguisher onto the circular portion of the wrench.
3. Insert the bar wrench through the handle opening of the discharge head (Fig. F).
4. Grasp both ends of the bar wrench and place one foot on the footrest. Turn the bar wrench counterclockwise until the discharge head begins to loosen. Once it turns easily, the bar wrench is no longer necessary. Continue turning the discharge head, by hand, until it is completely detached from the agent cartridge.
5. Discard the spent agent cartridge following the Disposal Procedure on page 8.

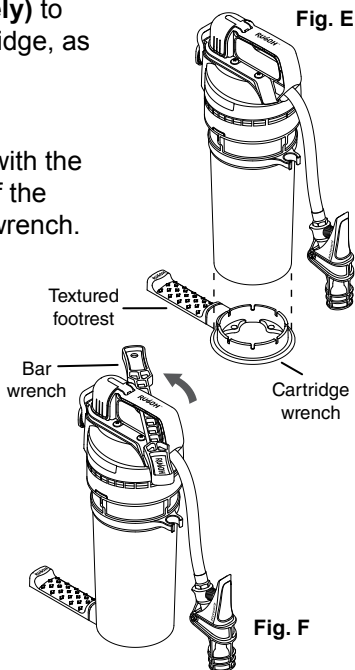

*Alternatively, fasten the cartridge wrench to a workbench or other flat surface with four screws.

STEP 5 *Remove parts from reload kit cap.*

1. Slide the CO₂ cartridge out of the reload kit cap (see Fig. A, page 1) and set aside for Step 10.
2. Open the hinged door on the reload cap (see Fig. B, page 1) and remove the replacement tamper seal, dust gasket, and red CO₂ cartridge gasket. Set aside for future use.

STEP 6 *Clean discharge head and install new dust gasket.*

1. Invert the discharge head. Remove the white silicone dust gasket from the center of the discharge head (Fig. G) and discard.
2. Clean the threads and inside sealing surfaces (Fig. G) with a cloth to remove any extinguishing agent residue. The sealing surfaces include the area immediately below the threads and the center cavity.

In order for the unit to seal properly, these areas must be clean. If you notice any caked-on extinguishing agent on these surfaces, use a small brush to loosen it.

3. Using compressed air, blow out the discharge head thoroughly. While squeezing the valve lever (Fig. C, page 2) to fully open the valve, blow air from the center of the discharge head through the hose and valve and then in the reverse direction. Refer to the Reloading Procedure video at www.rusoh.com.
4. Install the new dust gasket in the inverted discharge head, as shown in Fig. G. Press around the outer edge of the gasket so it is securely positioned.

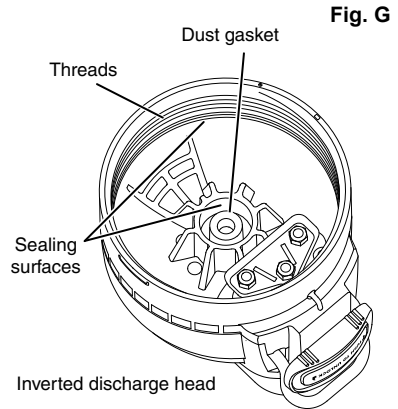

STEP 7 *Inspect unit for damage.*

1. Visually inspect the discharge head, hose, and valve assembly. If damage is found, replace components per the Self Service Manual.
2. Check to make sure the puncture lever is operating correctly. With the lock (Fig. C, page 2) in the unlocked (vertical) position, press down on the puncture lever a few times to ensure it moves freely and snaps back into position.

STEP 8 *Remove reload kit cap from replacement agent cartridge.*

Use the Eliminator™ wrench set (sold separately) to loosen the reload kit cap, per the method described below.

IMPORTANT: Always keep the agent cartridge on a level surface to prevent extinguishing agent from spilling.

1. Place the cartridge wrench with the textured footrest facing up. Set the bottom of the replacement agent cartridge onto the circular portion of the wrench.
2. Insert the bar wrench in the handle recess on the reload kit cap (Fig. H).
3. Grasp both ends of the bar wrench and place one foot on the footrest. Turn the bar wrench counterclockwise until the cap begins to loosen. Once it turns easily, the bar wrench is no longer necessary. Continue turning the cap, by hand, until it is completely detached from the agent cartridge. Discard the cap in a plastic recycling receptacle.

4. Once the reload kit cap is removed, use a small brush and clean off any dry chemical on the gray mixing tube cover (Fig. I). Then cut the black band on the bottom of the cover. Slowly remove the gray cover and discard.
5. Verify the two smaller red O-rings on the mixing tube and the large red O-ring on the outer threads on the replacement agent cartridge (Fig. I) are clean, well lubricated, and free of dry chemical.
6. If the O-rings have any dry chemical on them, remove each of the O-rings and wipe them off with a dry cloth. Once the O-rings are removed, clean the O-ring grooves on the agent cartridge and mixing tube with a dry cloth or small brush.
7. If needed, relubricate the O-rings and O-ring grooves with a generous amount of petroleum jelly. Reinstall the O-rings in their grooves on the agent cartridge. **IMPORTANT:** To ensure a working fire extinguisher, the O-rings must be properly seated in their grooves. Wipe away excess lubrication on the agent cartridge and mixing tube.

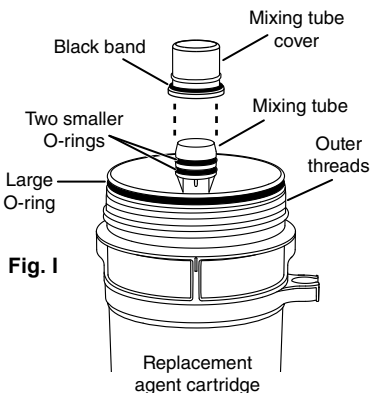
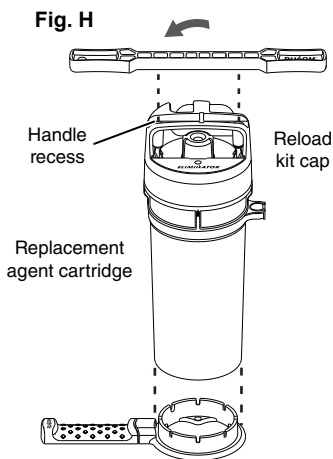

STEP 9 *Attach discharge head to new agent cartridge.*

⚠ WARNING! Do not refill or reuse the agent cartridge. It is designed to be factory filled and factory sealed to meet performance specifications. **Uninstalling and then reinstalling the same agent cartridge will void the warranty.**

1. For easier installation, apply a small amount of petroleum jelly to the discharge head sealing surfaces (Fig. G, page 4). Refer to the Reloading Procedure video at www.rusoh.com.
2. Place the discharge head on the agent cartridge. While holding onto the discharge head handle, turn the discharge head clockwise until snug. The turning resistance will become noticeably harder as the large O-ring begins to contact the sealing surface of the discharge head (Fig. G, page 4). Use the bar wrench, if necessary, to fully tighten the unit. When correctly installed, the red alignment rib on the agent cartridge will be within the red alignment marking on the discharge head (Fig. J).

NOTICE: There is a stop tab to prevent overrotation. If you feel the unit hit this tab, stop turning the discharge head.

3. Rotate the hose strap so the clip is aligned with the hose. Secure the hose by pushing it into the clip until it snaps into position. For compact storage, grasp the hose with one hand and the valve with the other and rotate the valve counterclockwise until the valve lever faces the wall.

Fig. J

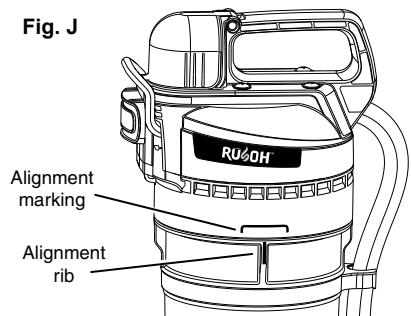

STEP 10 *Install new CO₂ cartridge.*

1. Ensure lock is in the locked (horizontal) position (Fig. L, page 7).
2. Lift up red CO₂ cartridge cover. Use a flashlight to verify the red CO₂ cartridge gasket is in place in bottom of threaded opening (Fig. K).

If it is missing, insert replacement gasket from reload cap (Fig. B, page 1). Use a needle nose pliers to gently pick up

Fig. K

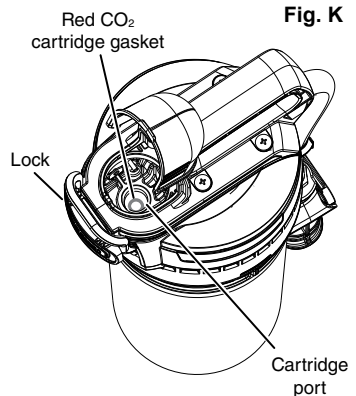

and drop the gasket into the cartridge port, making sure the gasket flange is facing down. Use the eraser end of a pencil and press the gasket into place.

IMPORTANT: It is crucial for extinguisher function that the gasket is correctly positioned in the cartridge port.

3. Install the new CO₂ cartridge by rotating it 8 full turns **counterclockwise** until tight. The use of a strap wrench is recommended.

NOTE: The CO₂ cartridge has reverse threads, so it turns opposite of normal threaded components.

4. If extinguisher will be mounted in bracket PN 40-393 or PN 40-404, use a strap wrench to turn the CO₂ cartridge an additional ¼ turn past hand tight.
5. Close red cover.

STEP 11 *Install new tamper seal.*

Position the new tamper seal so the text is right side up and the snap hooks align with the lock openings. Using two fingers, gently press the tamper seal arrows (Fig. L) until the seal locks into position on both sides of the lock.

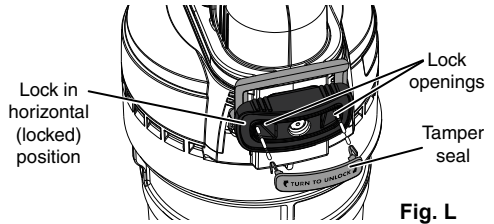

STEP 12 *Fluff the agent cartridge.*

Invert the extinguisher. Turn the Rusoh™ wheel (Fig. M) on the bottom of the unit back and forth several times until it turns freely. Then turn the wheel about three full rotations. The wheel should turn smoothly.

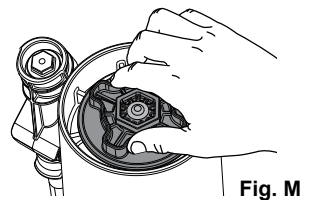

ELIMINATOR™ DISPOSAL PROCEDURE

⚠ DANGER! If extinguisher is damaged and has not been discharged, do NOT pressurize unit or puncture CO₂ cartridge.

IMPORTANT: Disposal must be performed in strict compliance with state and local waste disposal policies. Please contact your local waste disposal center, recycling center, hazardous waste authorities, or the Rusoh Customer Service Department at 1-800-318-2944 for details. You can also search Earth911.com for a recycling solution near you. **Do not dispose of the Eliminator™ fire extinguisher in a regular trash receptacle.**

1. If the Eliminator™ has been used and is undamaged, take it outside to verify that it has been fully discharged. Follow the T-P-A-S-S instructions in your Owner's Manual, even if you believe that you have previously discharged the unit. Aim the discharge near trees or bushes that have a higher resistance to acidic-type fertilizer. Avoid flowers and grasses.
2. Remove the CO₂ cartridge from the Eliminator™ discharge head and confirm that it is punctured. If it is not, return cartridge to the unit and repeat the discharge procedure outlined in step 1 above.
3. Place the punctured CO₂ cartridge in any recycling bin that accepts metals.
4. Place extinguisher in a plastic recycling receptacle.

CUSTOMER SERVICE INFORMATION

If you have any questions regarding the operation of your Eliminator™ fire extinguisher, contact us by any of these methods:

- Call 1-800-318-2944 weekdays 8:00 AM to 4:00 PM (Central Time)
- Email us at contact@rusoh.com
- Write: RUSOH, Inc.
Customer Service Department
3925 North Hastings Way
Eau Claire, WI 54703-3703

See the Self Service Manual for instructions on replacing the hose strap, Rusoh™ wheel, handle assembly, valve assembly, and instruction label.



A product of

RUSOH_U
www.rusoh.com